

HYDRO-AIR

Exclusively From Water Systems

PERMA TANK PUTS IT AIR SIDE

A factory installed **Pump Control Module** puts the pressure switch, gauge and air valve on the *air* side of the tank, *where they belong!*

The innovative **HYDRO-AIR** Pump Control Module is factory installed to save you time and money. It is the fastest and easiest way to install a pump tank.

Consider The Advantages:

- Easier/faster installation
- Eliminates tank tee package.
- Switch and gauge are protected from liming, scaling or freezing.
- Electrical connections in a safer, more convenient location. More than 18" off the ground.
- Schedule 80 nipple factory installed.
- Attractive, more professional looking installation. Plumbing is on the back where it belongs.
- Rapid cycle caused by hydraulic shock is eliminated.
- Service life of switch and gauge extended.
- Relief and drain valve can be installed in the most convenient location.

DESIGNED • ENGINEERED
& ASSEMBLED IN THE
USA ★

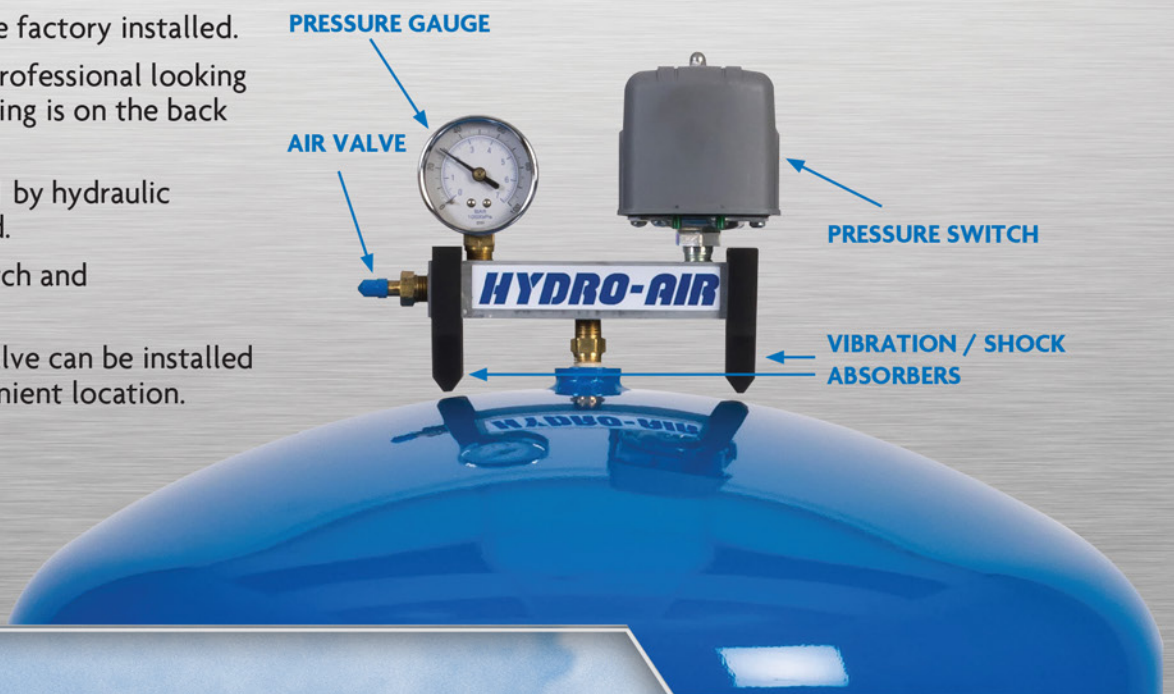

Diaphragm Pump Tanks

Gets The Job Done, Faster, Easier, Better.

The most difficult and time consuming part of installing pump tanks is the pressure switch and gauge being on the floor. This requires that the installer spend time on his hands and knees.

The Benefit:

Put the pressure switch, gauge and air valve together, on top of the tank, **where they belong!** The tank is equipped with a schedule 80, threaded plastic nipple, outside the base. This results in a clear view of the gauge, and installing it on the air side eliminates water vibration! The **Hydro-Air** way provides a more professional looking installation.

Volume, Dimension and Weight Specifications

Model Number	Vol. (Gallons)	"A" Overall Height/Length	"B" To Center of Water Inlet	"C" Diameter	"D" Tank Height/Length	"E" Module Height	"F" Pipe Size	Weight (Lbs)
PCM-20	20	38 1/4	2 1/4"	15 3/8"	32 3/4"	5 1/2"	1"	31
PCM-36	36	33 1/8	2 1/4"	20"	32 5/8"	5 1/2"	1 1/4"	46
PCM-52	52	44 1/8	2 1/4"	23 3/8"	38 5/8"	5 1/2"	1 1/4"	78
PCM-86	86	64 1/2	2 1/4"	23 3/8"	59"	5 1/2"	1 1/4"	106
PCMH-20	20	29 1/8	—	15 3/8"	17 1/2"	—	1	25.5

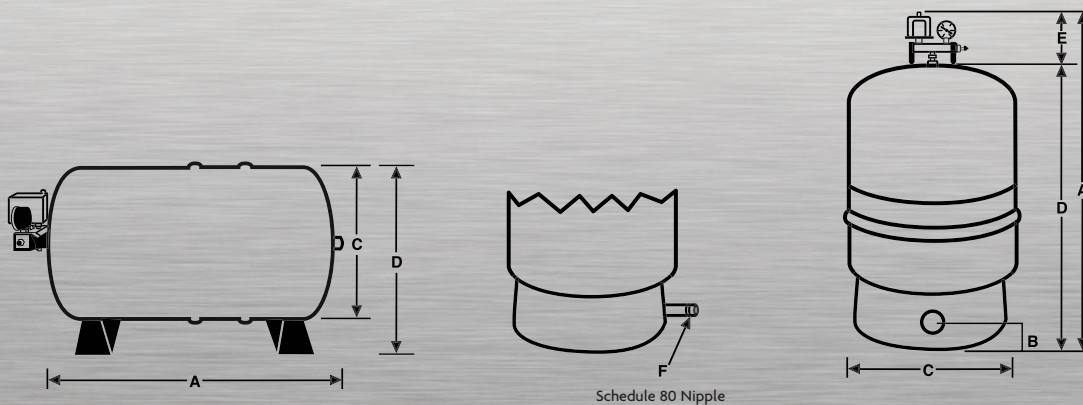

A. O. Smith reserves the right to make product changes or improvements at any time without notice.

For more information on Perma Tank, contact:
Water Systems - An A. O. Smith Company
500 Tennessee Waltz Parkway Ashland City, TN 37015
800-365-4300 www.wstanks.com

WATER SYSTEMS
AN A. O. SMITH COMPANY